

HighSpeed CNC Coiling and Bending Machine for the Production of Parts and Frames from Wire and Profiled Materials



BM 36 *HighSpeed*
BM 43 *HighSpeed*

BM 36 *HighSpeed*

BM 43 *HighSpeed*

Our Accomplishments for your Benefit

- The highly dynamic drives and the 5-year license of *iQsmartbend* of the new BM HighSpeed series guarantee highest quality of parts and economic efficiency
- The machine's innovative design and new developments increase its dynamics while maintaining its well-known reliability
- The servomotor-driven displacement of the feed unit enhances the quality of parts and offers highest degrees of geometrical freedom due to variable bend-back clearances
- The high-end control WPS 3.2 EasyWay features an intuitive user interface, it reduces set-up times to a minimum and enables an easy production of complicated parts
- The HighSpeed series offers maximum flexibility and combines the following options in one modular concept: servomotor-displaceable feed unit, rotary straightening (BM 43 HS) and displaceable cutting unit (BM 43 HS)
- The new chamfering device without extraction unit ensures an economical production of wire parts with chamfered ends

Design Features

- Newly developed, easy to maintain and more efficient feed unit
- Enhanced cutting unit with maximum bending freedom for geometries that require bend-back clearances
- Manual adjustment of feed unit on linear guides or servomotor-displaceable feed unit as an option
- The tubular wire guide and the displaceable feed unit increase process reliability and improve the machine performance when processing wire diameters smaller than 2 mm or soft materials.
- The light-weight bending head with low inertia guarantees high process speeds

▼ WAFIOS Programming System WPS 3.2 EasyWay

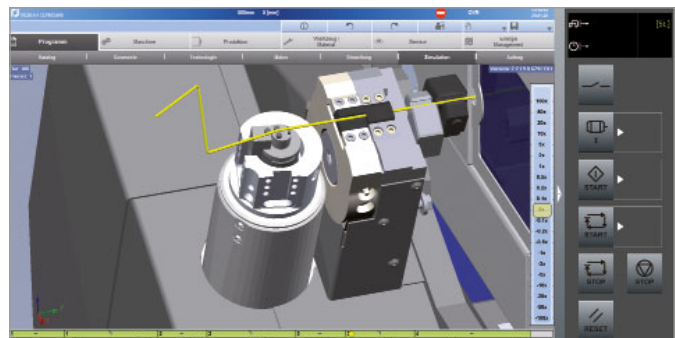

Control System

- User-friendly and quick set-up due to hand-held operating device with touchscreen
- WAFIOS WPS 3.2 EasyWay user interface enables the programming of lengths, angles or coordinates
- Quick programming of tools, materials and bending programs

WAFIOS Technology: For Those Who Demand the Best! Solutions for Process Optimization (*iQs*)

- *iQwire*: Real-time simulation for calculating cycle times and for collision control (option)
- *iQwire+*: Automatic calculation of a production process free from collisions, positioning of the table axis and optimized calculation of cycle times (option)
- *iQinspect*: Import/export of nominal geometry data and correction data from external measuring system to WAFIOS programming system WPS 3 (option)
- *iQbendcontrol*: Visual camera system for measuring and regulating bending angles (option)

Variable, Flexible and Productive – WAFIOS CNC Bending and Coiling Centers BM

Maximum Performance for your Parts

The BM HighSpeed series is the most efficient generation of machines for manufacturing bent wire parts of high complexity.

The HighSpeed machines, which include both highly dynamic drives and a 5-year license *iQsmartbend*, can be used to optimize unit costs across the entire range of parts. The high-end bending machine, equipped with intelligent software, optimizes all bending programs fully automatically based on its digital twin. As a result, the output of the BM 36 HS could be increased by up to 40%.

The BM series' great number of available options make it easy to customize to meet market requirements. The machine's modern and innovative design highlights the technological leadership of the new BM generation.

▼ Feed unit and straightening unit of the BM 36 HS

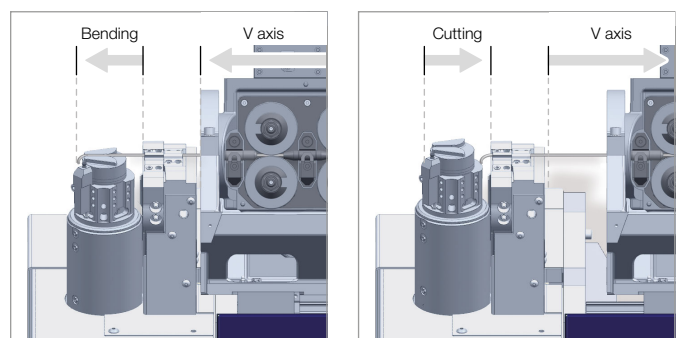
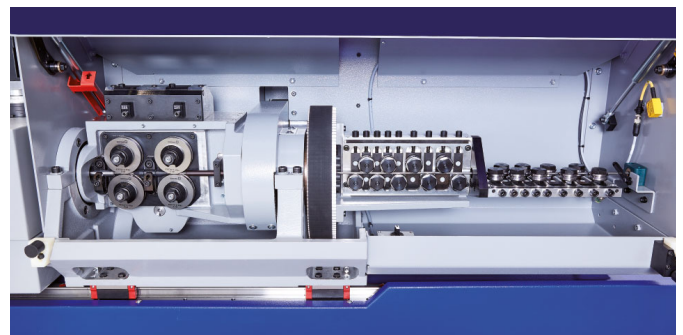

▲ Servomotor-driven displacement of the feed unit for highest degrees of geometrical freedom

Quality

For more than 125 years, the name of WAFIOS has been synonymous with highest quality, safety standards, and technical innovations in the German machine manufacturing industry.

Reliability

Strict quality controls, state-of-the-art production systems, and many years of experience guarantee that your investment is safe in our hands. Our global service network ensures high availability of WAFIOS machinery.

Cost efficiency

High production output and a long service life will save money and shorten the amortization time of your investment.

▼ Chamfering device for the production of wire parts with chamfered ends

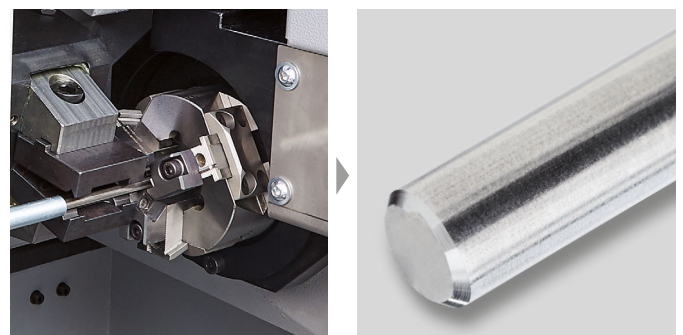

Technical Data	BM 36 HighSpeed	BM 43 HighSpeed
Wire diameter range: 600 N/mm ² 1,200 N/mm ² 1,900 N/mm ²	2.0 – 6.5 mm 2.0 – 4.5 mm 2.0 – 3.6 mm	3.0 – 8.0 mm 3.0 – 5.0 mm 3.0 – 4.3 mm
Extension of wire range diameter (option)	From wire Ø 1.5 mm	From wire Ø 1.5 mm
Rotary angle, mandrel axis	Infinite	Infinite
Angle of rotation of bending axis	Infinite	Infinite
Bending head, up/down stroke	+10 mm / –80 mm	+18 mm / –122 mm
Bending head transverse stroke	+40 mm / –40 mm	+60 mm / –60 mm
Bend-back clearance	160 / 500 / 800 / 1,100 mm Option: Infinite adjustment via CNC axis	200 / 500 / 800 / 1100 / 1,400 mm Option: Infinite adjustment via CNC axis
Bending head positioning (option)	+30° fix	+25° fix
CNC support plate, stroke (option)	+25 mm / -200 mm	+25 mm / -235 mm
Feed speed	max. 140 m/min	max. 140 m/min
Bending moment, tool holding fixture	ca. 180 Nm	ca. 225 Nm
Number of CNC axes	7 (max. 14 as an option)	7 (max. 17 as an option)

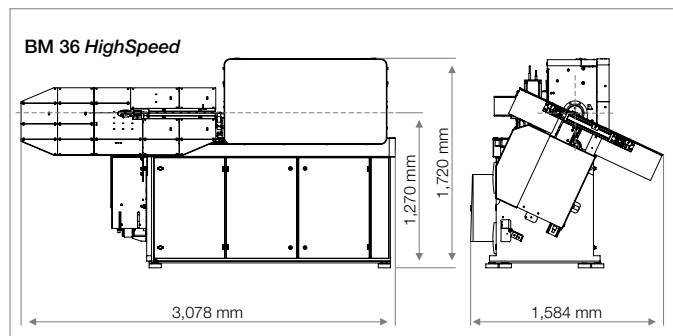

WAFIOS Machinery Corp.
27 Northeast Industrial Road
Branford, CT 06405 USA
Phone (203) 481-5555
Fax (203) 481-9854
sales@wafios.us
www.wafios.us

WAFIOS Machinery Corp.
9830 W. 190th Street, Unit D
Mokena, IL 60448 USA

Precision Machinery for Wire and Tube