

CNC Coiling and Bending Machines for the Production of Two- and Three-Dimensional Parts and Frames from Wire and Profiled Materials



BM 60

BM 60

▼ Bending head and cutting unit



▼ Feed unit and straightening unit stationary mounted in one of four positions, adjustable by handwheel (option) or motor (option)

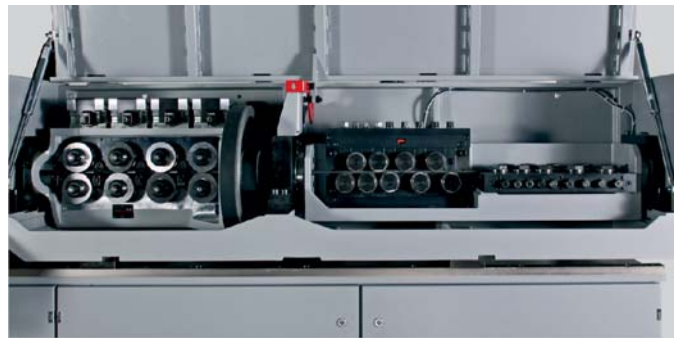

Our Accomplishments for your Benefit

- Tried and tested, successful machine structure
- Most of the tools from predecessor machines can be used
- Higher process safety thanks to adjustable bend-back clearance
- Consistent standard operating system

Design Features

- The basic version of the BM 60 has six CNC axes, upgradable to max. 18 CNC axes (option)
- Robust feed unit for advancing and rotating the wire, displaceable together with roller or rotary straightener for adjusting the bend-back clearance (option)
- Fast, CNC-controlled unit with optimized cycle times (displaceable as an option)
- Reinforced cutting unit for spring steel (option)
- Extended operating range for smaller wire diameters (option)
- Versatile bending head with large bending clearance and flexible application possibilities thanks to the infinitely rotating bending and mandrel axis as well as long transverse and up/down strokes
- Feeding and bending tools are compatible with predecessor models
- User-friendly machine control WAFIOS WPS 3.2 EasyWay with plain-language programming of lengths/angles and coordinates, linking of all machine components, graphical user interface
- Operating safety due to wear-resistant machine concept
- Combination straighteners cover the entire operating range of the machine

Operation

- User-friendly and fast set-up thanks to hand-held operating device with touchscreen
- Reduced set-up times due to ergonomic access to all tool positions as well as simple and fast programming of tools, material properties and bending programs with WPS 3.2 EasyWay
- *iQbend*: automatic optimization of CNC program sequences with regard to the geometry of the bent part (option)
- *iQinspect*: Import/export of nominal data or correction data from external measuring system to WAFIOS Programming System WPS 3.2 EasyWay (option)

▼ Bending after the cut

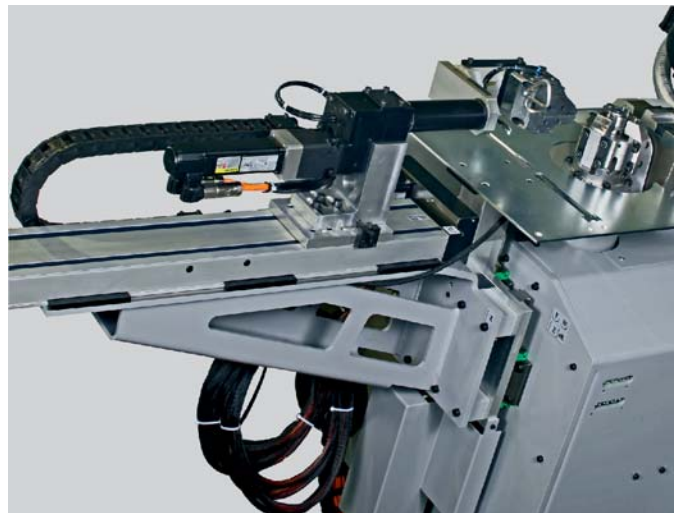

Safe, Efficient and Profitable – WAFIOS BM 60 CNC Coiling and Bending Machine

Trend-setting machine concept

The WAFIOS BM 60 has been designed for the production of two- and three-dimensional parts as well as frames from wire and profiled material. For the first time ever, it offers a completely new modular design.

Modularity:

The WAFIOS BM 60 combines the well-known possibilities and functions of the B and BMU series in an extensive system of modular options. Thus the basic machine can be equipped with 6 - 18 CNC axes - just as required by the customer.

Thanks to the optional adjustment of the distance between feed unit, cutting unit and bending head, the BM 60 enables the user to carry out even highly critical bending and coiling operations precisely and with repeat accuracy while reaching highest outputs. Moreover, the well-proven tools of the BM 60's predecessor models can be used for the BM 60 as well.

The stationary mounted bending head is characterized by its robustness at high bending speeds. As an option, the bending head can be manually swiveled between 0° and 25°.

Sophisticated safety concept, CE-compliant according to Machinery Directive 2006/42/EC, including as system in conjunction with a pay-off unit and protective fence.

Quality

For over a 120 years, the name WAFIOS has represented the highest level of quality expectations, safety standards and German technical innovation related to the engineering of manufacturing systems.

Reliability

Strict quality controls, state-of-the-art production systems and many years of experience guarantee that your investment is in safe hands. Our global service network ensures high availability of WAFIOS machinery.

Efficiency

High production output and a long service life will save money and shorten the amortization time of your investment



▲ Multi-radii bending tool for bending and free-form bending



▲ 4-Pin bending tool, type 5

▼ Displaceable cutting unit, position 1



▼ Displaceable cutting unit, position 2



▲ iQbend in WPS 3.2 EasyWay



▲ User-friendly WAFIOS programming system WPS 3.2 EasyWay

Technical Data	BM 60
Operating range, wire Ø 600 N/mm ² 1 200 N/mm ² 1 900 N/mm ²	6,0 – 13,0 mm 6,0 – 8,5 mm 6,0 – 7,0 mm
Extended operating range (opt.)	Ab Draht-Ø 3,0 mm
Feed rollers	4 Pairs
Rotary angle, mandrel axis	Infinite
Rotary angle, bending axis	Infinite
Bending head, up/down stroke	+100 mm / -100 mm
Lateral stroke of bending head	+100 mm / -50 mm
Bend-back clear., manual (mm)	500 / 800 / 1 100 / 1 400
Bend-back clear., motor-adj. (mm) (option)	500 - 1 400
Bending head positioning	+25°/0°
Stroke of CNC support plate (opt.)	+25 mm / -275 mm
Max. feed speed	120 m/min
Bending torque	ca. 1 700 Nm
Number of standard CNC axes	6 (8 / max.18)

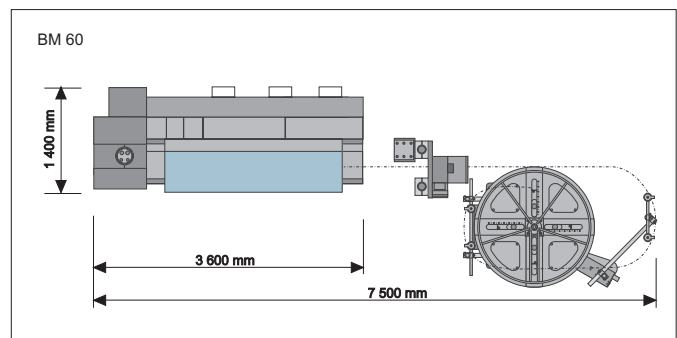

WAFIOS Machinery Corp.
27 Northeast Industrial Road
Branford, CT 06405 USA
Phone: (203) 481-5555
Fax: (203) 481-9854
sales@wafios.us
www.wafios.us

Midwest Technical Center
9830 W. 190th Street, Unit D
Mokena, IL 60448 USA

Precision Machinery for Wire and Tube