

CNC multiple-head tube bending machine for the production of complex, three-dimensionally bent parts



BL 10

BL 10

▼ Bending station with transfer system

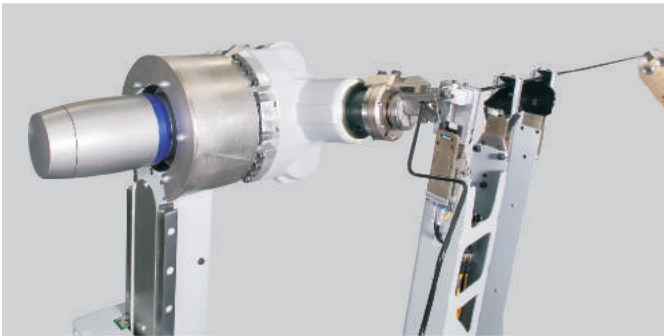

▼ Maximum flexibility with large bending space



Our Accomplishments for your Benefit

- Broad range of parts possible, including with complex geometries thanks to the special kinematics of the tube bending machine
- Increase in output even with highly complex and unstable parts through automatic optimization of the bending processes and part transfer thanks to *iQsmartbend*
- Maximum repeat accuracy thanks to rotary-draw bending integrated in one-of-a-kind, universal, low-wear tool concept
- One-of-a-kind, innovative loading concept solves insertion problems experienced with long, unstable lines
- Reduction in unit costs due to minimized non-productive times, rapid part transfer, low-wear tool drives, space-saving machine concept, and automatic optimization of bending processes

Control

- Convenient sequence programming thanks to WAFIOS WPS 3.2 Easyway with EasyTab
- Full HD multi-touch 24" monitor
- Sequence simulation, distribution across multiple stations
- Online interface
- *iQfunctions* – more efficiency through intelligent process control

Design features

- Left, right, rotary-draw bending, and roll bending in up to three planes combined in one standard tool
- Low tool costs thanks to simple tool design
- State-of-the-art control technology with minimized non-productive times
- Parallel operating sequences possible
- Modular structure with 2-, 4- or 6-head transfer
- High repeat accuracy thanks to wear-free bending technology
- Line stabilization with grippers providing support in front of the bending head

▼ BL 10-6

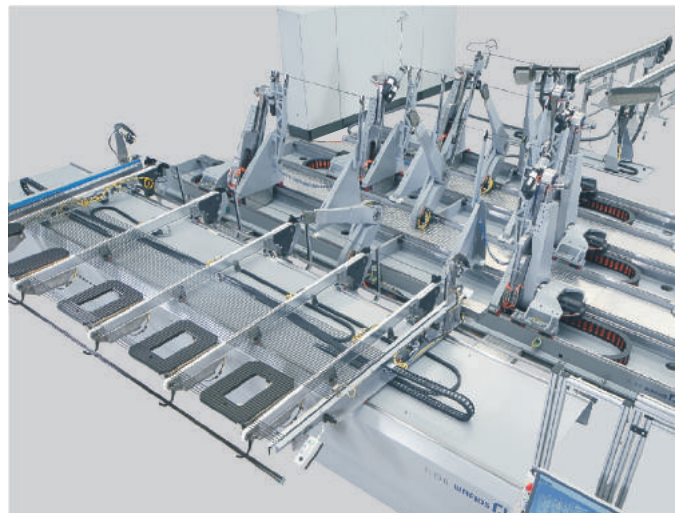

Powerful, flexible, and efficient – a new kind of multiple-head bending machine

One-of-a-kind bending concept

Extremely high degrees of freedom and parallel operating sequences ensure a level of productivity and output that has never been seen before on the market. The space-saving machine concept enables lines up to 6,000 mm in length to be bent to an extremely high quality and repeat accuracy thanks to stabilizing grippers that are used as a support directly in front of the head.

In the BL 10, the award-winning *iQsmartbend* control solution (optional) is also incorporated in tube bending for the first time. It is a software solution for the automatic optimization of bent parts to enhance quality and performance by calculating the ideal tool motion profiles.

Compact, slimline, and freely positionable bending heads offer extremely high degrees of freedom and combine both rotary-draw bending and roll bending in up to three planes. The combination of these methods enables bending close to screw connections or the hoses often used in brake pipes, for example.

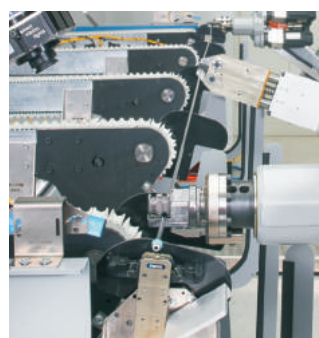

▲ Free positioning of the bending heads



▲ High flexibility for part geometries

Quality

For more than 120 years the name WAFIOS has stood for the highest in terms of quality expectations, safety standards and technical innovation in German manufacturing systems engineering.

Reliability

Strict quality controls, state-of-the-art production systems and many years of experience guarantee that your investment is in safe hands. Our global service network ensures high availability of WAFIOS machinery.

Efficiency

High production output and a long service life will save money and shorten the amortization time of your investment.

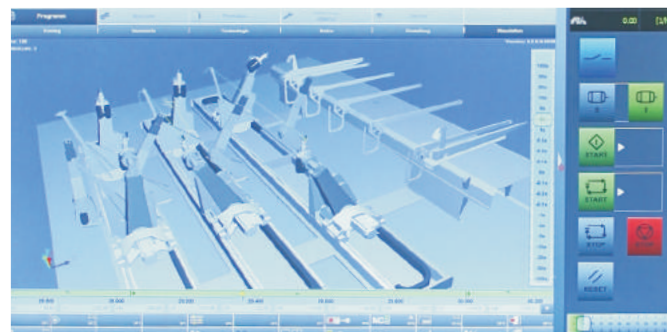

▲ User-friendly control with WAFIOS WPS 3.2 EasyWay

Technical data	BL 10
Tube ø: steel tensile strength up to 400 N/mm ²	4.0 – 10.0 x 1.0 mm
Tube ø: aluminum tensile strength up to 270 N/mm ²	4.0 – 12.7 x 1.0 mm
Tube length	up to 6 000 mm
Operating range extension	Option
<i>iQtube</i> bending simulation	Option
Length measuring device	Option
Camera system	Option
Color detection	Option
Movable auxiliary grippers	Option
Ext. programming station	Option
<i>iQinspect</i> measuring cell connection	Option
Weight (BL 10-6)	ca. 16 000 kg
Machine control	WPS 3.2 EasyWay

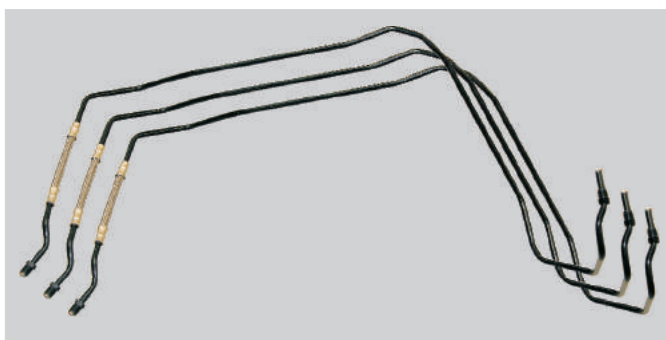
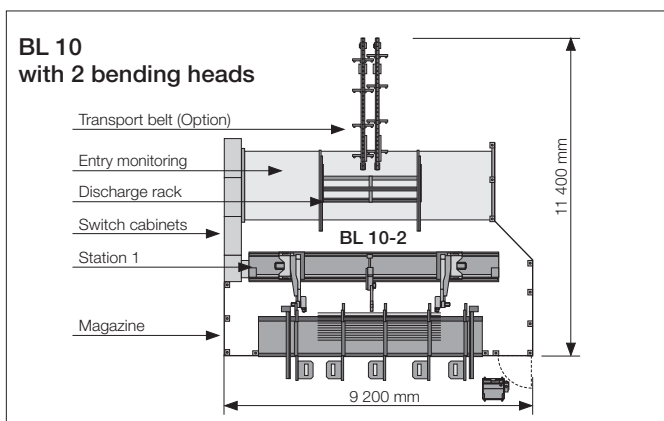
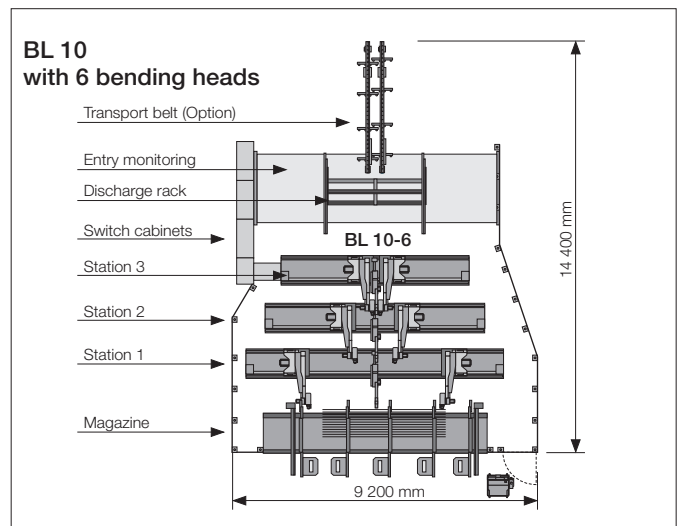
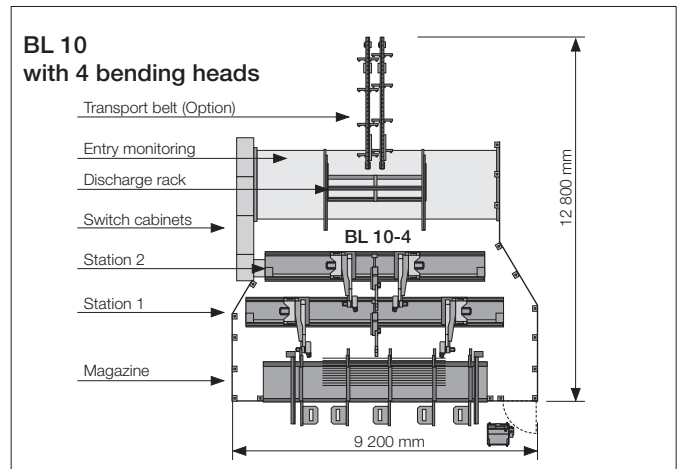

WAFIOS Machinery Corp.
 27 Northeast Industrial Road
 Branford, CT 06405 USA
 Phone: (203) 481-5555
 Fax: (203) 481-9854
 sales@wafios.us
 www.wafios.us

Midwest Technical Center
 9830 W. 190th Street, Unit D
 Mokena, IL 60448 USA

Precision Machinery for Wire and Tube