

END WORKING SYSTEMS

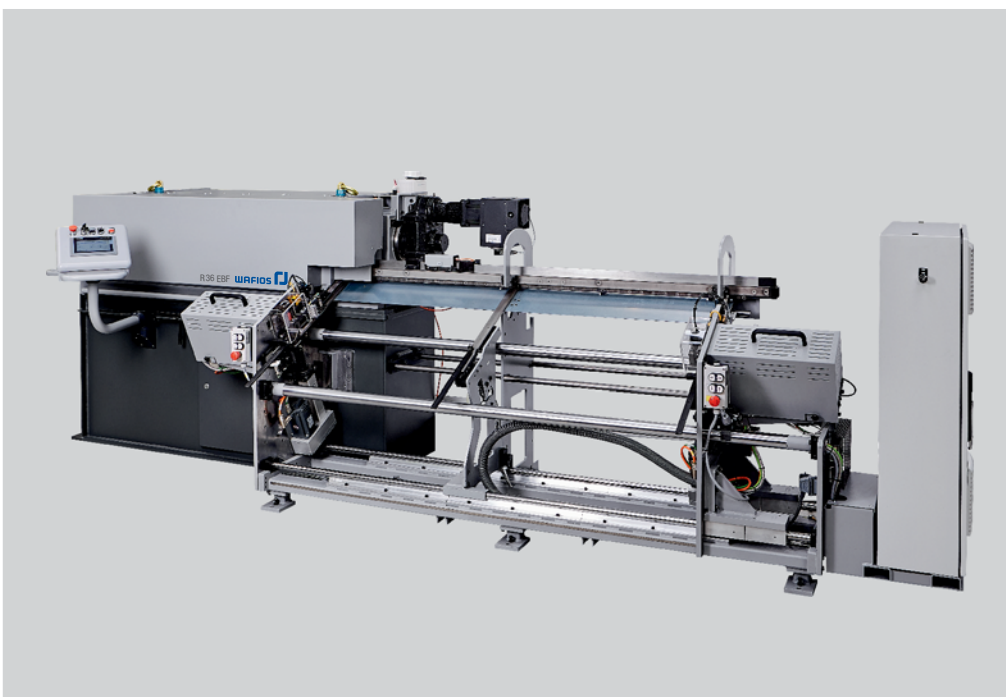

R 23/36 EBS
R 36/45 EBF
AF 700

R 23/36 EBS R 36/45 EBF AF 700

▼ Simultaneous machining of rod ends using chamfering heads (R 36/45 EBF)

▼ Simultaneous machining of rod ends using grinding CBN grinding rolls and brushes (Option) (R 23/36 EBS)



Our Accomplishments for your Benefit:

- Machining both rod ends simultaneously
- Minimization of set-up times
- Proven and optimized, language-neutral operator guidance
- Improved working conditions due to safety instructions and electronic operating instructions
- CE-compliant integration of protective devices in the basic machine
- Option mobile version: EBF/EBS are plug-in on basic machine.
- Advantage: Machine can be operated with and without end processing. EBF or EBS can also be operated on another machine of the same type, provided that the basic machines are equipped with plug-in option.

EBF - End working system for simultaneous chamfering of both rod ends by carbide-tipped chamfering heads

Separate drives for feed and clamping, which allows different chamfers, feed rates and rotational speeds on rod ends.
Possibilities of end working : chamfers 15- 60 °, round chamfer, facing, tip (on request)
Option intermediate station - installation/extension can now be realized without dismantling the chamfering unit on the left-hand side

Version clamping done by pneumatic cylinders

- Entrance version with an output of up to 110 pieces per minute

Version clamping done by electric cylinders

- Output up to 130 pieces per minute
- Reduced set-up times and optimized operability
- Option short length 130 - 190 mm

EBS - End working system for deburring the edges on both rod ends

- Grinding units with CBN grinding rolls with high durations, optional grinding belts
- Optimized usability due to shortened transport distance
- Optional brush station and intermediate station



▲ Graphical operator guidance (EBS)

▼ 30° / 45° facing, round, tip chamfer on request (EBF)

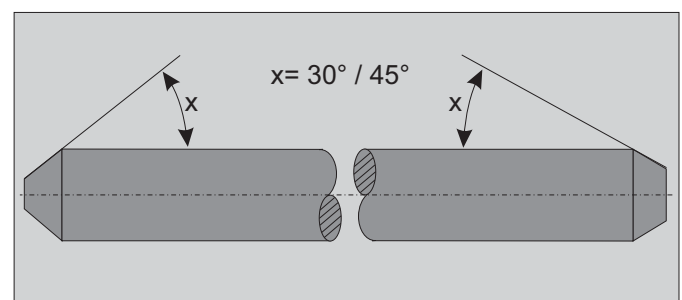

Quality, Reliability and Efficiency – WAFIOS End Working Systems

New Definition of Productivity

Straightening machines combined with chamfering unit for producing chamfered wire sections. The directly attached chamfering unit can be variably used and is highly effective.

The rods ejected by the straightening machine, are parallelly aligned and stored in a magazine.

EBS:

A feeding unit feeds the rods synchronously with the cut of the straightener into the transport belt. The rods pass by some CBN grinding rolls which provide the two deburred (Option) rod ends. The grinding burr can then be removed by brushes.

EBF:

Feeding units lift the rods out of the magazine and position and clamp them in accordance with the cycle of the straightening machine. Then the rod ends are chamfered by the carbide-tipped chamfering heads.

Quality

For more than 125 years, the name of WAFIOS has been synonymous with highest quality, safety standards and technical innovations in the German machine manufacturing industry.

Reliability

Strict quality controls, state-of-the-art production systems and many years of experience guarantee that your investment is safe in our hands. Our global service network ensures high availability of WAFIOS machinery.

Efficiency

High production output and a long service life will save money and shorten the amortization time of your investment.

AF 700

High-speed chamfering machine, with infinitely adjustable mechanical main drive.

- Automatic separation of rods from magazine
- Clamping of wire rods during the chamfering process
- Fast or regular, feed speed for cutting heads
- Chamfering of the bar ends with carbide-tipped chamfering heads (30°/45°, facing and round chamfer on request)
- Rod length steplessly adjustable using a handwheel
- Adjustable speed of the chamfering spindle by means of frequency converter

▼ AF 700

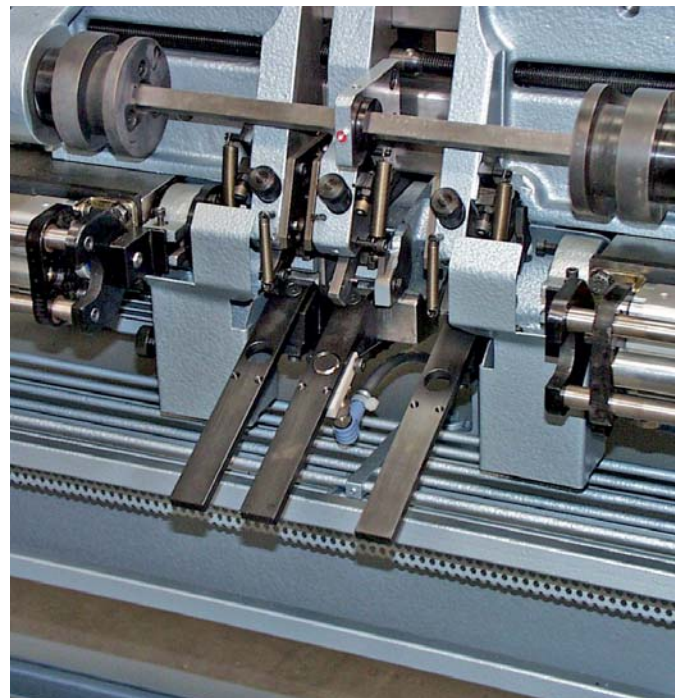

Technical data	R 23 EBS	R 36 EBS
Wire diameter (RM 600 - 800 N/mm ²)	1.5 - 4.0 mm	2.5 - 7.0 mm
Cutting lengths (mm) with additional intermediate stations	150-1,000/2,000/3,000	150-1,000/2,000/3,000
Output of rods per minute	max. 180	max. 180

Technical data	R 36 EBF	R 36B EBF	R 45 EBF	R 45B EBF
Wire diameter (RM 600 - 800 N/mm ²)	3.0 - 7.0 mm	3.0 - 8.0 mm	4.0 - 10.0 mm	4.0 - 12.0 mm
Clamping done by pneumatic cylinders				
Cutting lengths (mm) with additional intermediate stations*	160-1,000/2,000/3,000	160-1,000/2,000/3,000	180-1,000/2,000/3,000	180-1,000/2,000/3,000
Output of rods per minute	max. 110	max. 110	max. 100	max. 100
Clamping done by electric cylinders				
Cutting lengths (mm) with intermediate stations*	190-1,000/2,000/3,000	190-1,000/2,000/3,000	190-1,000/2,000/3,000	190-1,000/2,000/3,000
Option short length version (mm)	130 - 190	130 - 190	130 - 190	130 - 190
Output of rods per minute	max. 130	max. 130	max. 130	max. 130

Technical data	AF 700
Wire diameter (RM 600 - 800 N/mm ²)	3,0 - 10,0 mm
Cutting lengths (mm)	80-880/1,500/2,380
Output of rods per minute	max. 120

*Option

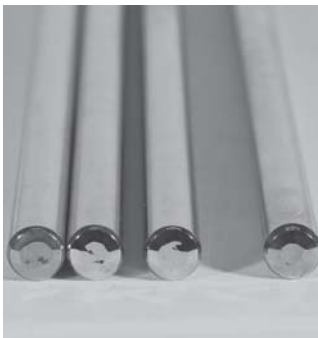

WAFIOS Machinery Corp.
27 Northeast Industrial Road
Branford, CT 06405 USA
Phone: (203) 481-5555
Fax: (203) 481-9854
sales@wafios.us
www.wafios.us

Midwest Technical Center
9830 W. 190th Street, Unit D
Mokena, IL 60448 USA

Precision Machinery for Wire and Tube